

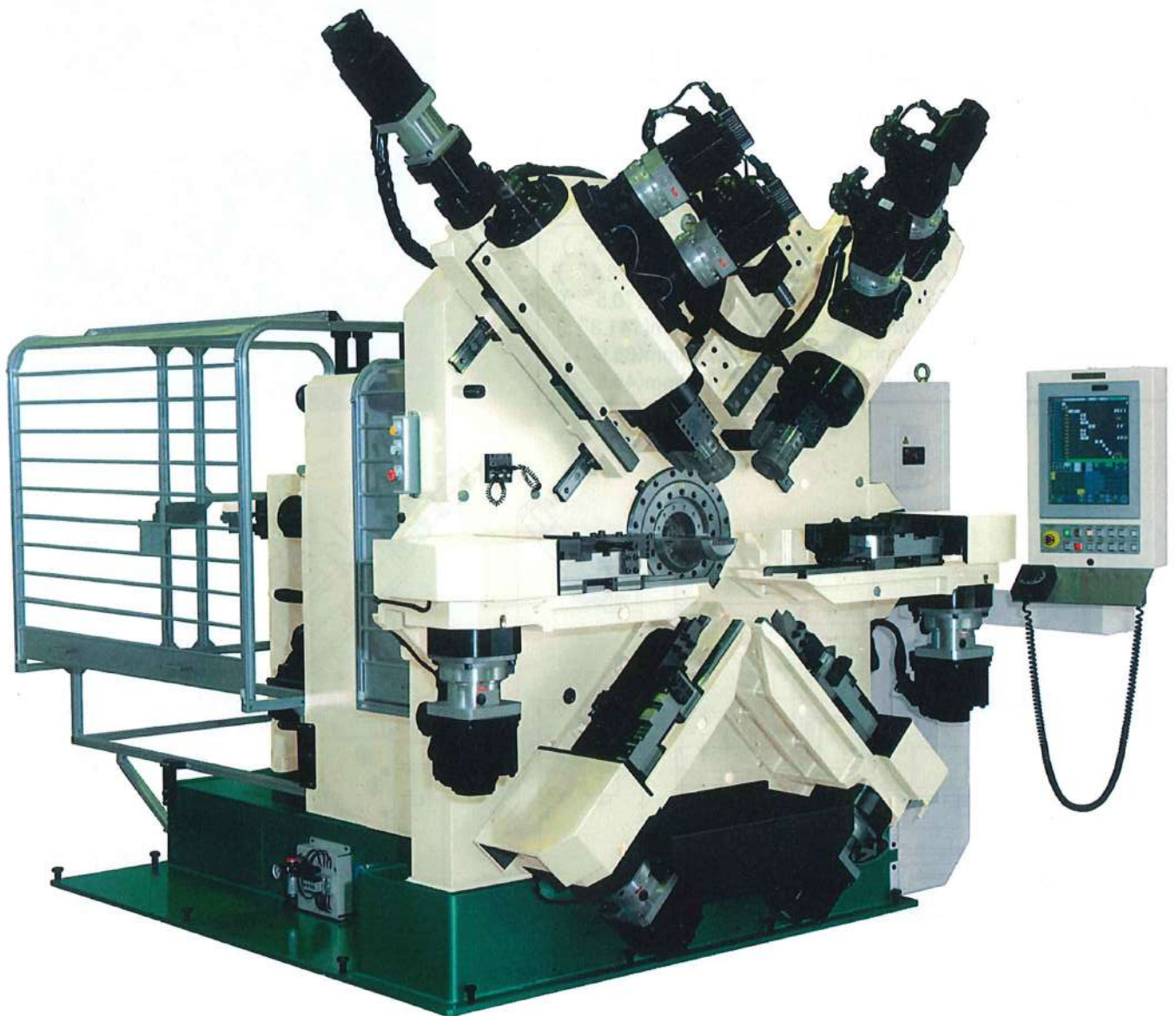

SHINKO

UF series

Universal Formers



UF-70H

新興機械工業株式会社
SHINKO MACHINERY CO., LTD.

機種選定表 Model Selection Chart

機種 Model	UF-70	UF70H	
対応線径 Wire Diameter	3.0~7.0mm .118" ~.276"	3.0~7.0mm .118" ~.276"	
送りロール連数 Pairs of Rollers	3	4	
最大線送り速度 Max Feeding Speed	90m/min 295ft./min.	67m/min 220ft./min.	
最大加工長さ Max. Length	270mm 10.63"	270mm 10.63"	
電源容量 Power Source	100A	150A	
重量 Weight	7,100Kg 15,800lb.	7,600Kg 16,900lb.	
寸法 Dimension	H	2,030mm(79.9")	2,500mm(98.5")
	W1	2,380mm(93.7")	2,600mm(102.4")
	W2	1,790mm(70.5")	1,790mm(70.5")
	L1	3,400mm(133.9")	3,600mm(141.8")
	L2	1,950mm(76.8")	2,200mm(86.6")
	WL	1,110mm(43.7")	1,180mm(46.5")

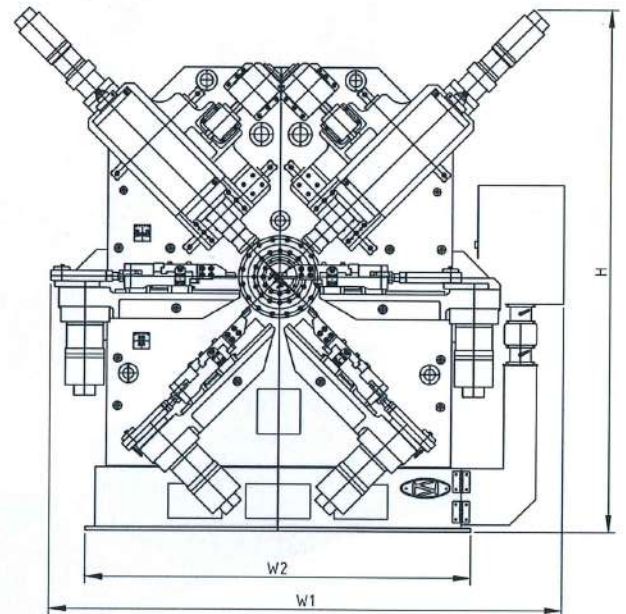
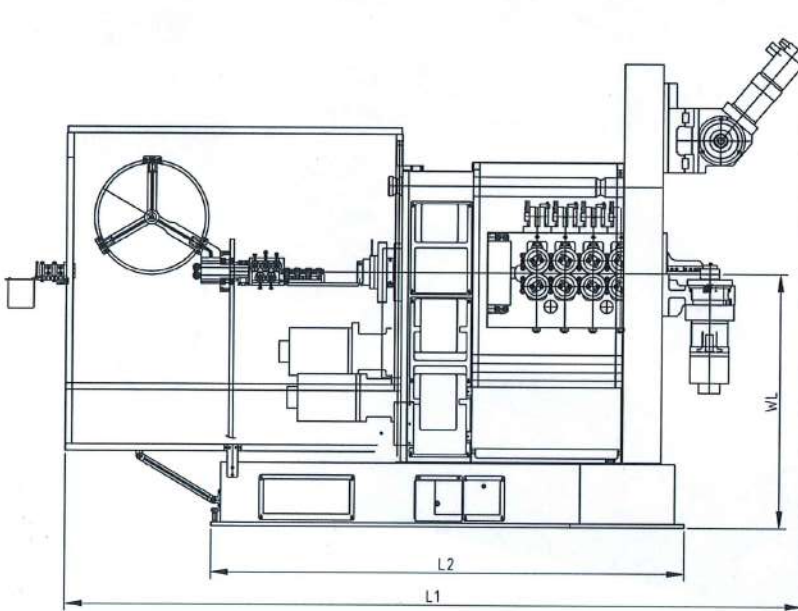

● このカタログに記載されている事項は予告無く変更されることがあります。
Because of continual design improvement, specifications are subject to change without notice.

新興機械工業株式会社
〒547-0001 大阪市平野区加美北3丁目17番25号
TEL : 06-6792-7388 FAX : 06-6794-1025
www.shinko-mach.co.jp

SHINKO MACHINERY CO., LTD.
3-17-25 Kamikita Hirano-ku, Osaka, Japan
TEL : +81-6-6794-6610 FAX : +81-6794-1025
E-mail : info@shinko-mach.co.jp